

# VascuLathe®-ASR and VascuLathe®-ACS

## Linear/Rotary Motion Platform

High integration linear/rotary motion platform

ER collet system for automated material clamping

Optional gripper assembly for tube advance

Advanced control architecture

Single or dual spindle configurations

Optional wet cutting

High-speed rotary option for rotational speeds up to 2000 rpm

VascuLathe® represents a revolutionary approach to satisfying the demanding requirements of stent manufacturing applications. The fully integrated motion system couples automated material handling functionality and wet cutting operation with high performance direct-drive linear and rotary motion capability.

### Integral Linear/Rotary

The integral linear-rotary design has much greater stiffness and lower moving mass resulting in an overall higher dynamic stiffness when compared to component-based systems. The resulting increased bandwidth provides throughput improvements on the order of two to five times when compared to traditional component-level manufacturing approaches, while still maintaining submicron tolerances on tight part geometries. The higher throughput of the VascuLathe® implies that fewer machines are required to produce an equivalent number of stents, resulting in lower total labor costs and reduced floor space requirements. Alternatively, the VascuLathe® can be used to meet increased product demand within the existing manufacturing space, saving the costs associated with facilities expansion.

### Automated Material Handling

The VascuLathe® is a complete motion and material handling subsystem. The system includes an automated, pneumatically activated ER collet assembly as well as an optional combined bushing/tube advance mechanism that enables the sequential, unattended manufacture of multiple stents from a single length of tubing material. A wet

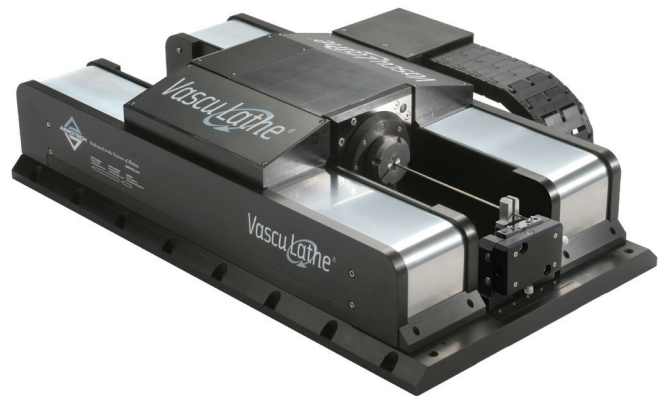

Patent No. 7,038,334  
Patent No. 7,105,956  
Patent No. 7,420,298

cutting configuration is also available for applications that require fluid delivery through the stent material during the manufacturing process.

### Advanced Control Architecture

The VascuLathe® is available with a powerful, yet intuitive Aerotech control system, with which a user can conveniently optimize the current, velocity, and position servo loops for maximum performance. Advanced trajectory generation capabilities such as multi-block look ahead minimize geometry errors in tight profiles by transparently regulating cutting speed. While our Position Synchronized Laser Firing Output (PSO) functionality automatically adjusts the laser pulse frequency to match the current cutting speed to maintain optimal laser power coupling.

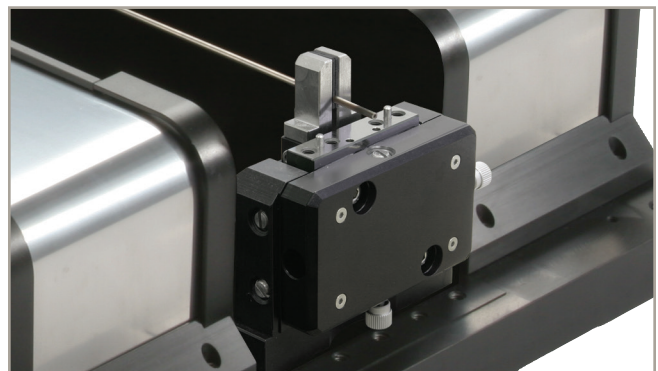

Optional gripper and bushing alignment platform for automated tube advance.

## Vasculathe®-ASR SPECIFICATIONS

Mechanical Specifications		Linear Axis		Rotary Axis
Travel		200 mm	300 mm	±360 deg. continuous
Accuracy		±1 µm		±73 µrad (±15 arc sec)
Bidirectional Repeatability		±0.5 µm		±15 µrad (±3 arc sec)
Straightness		±2 µm	±3 µm	N/A
Flatness		±2 µm	±3 µm	N/A
Pitch		39 µrad (8 arc sec)	49 µrad (10 arc sec)	N/A
Yaw		39 µrad (8 arc sec)	49 µrad (10 arc sec)	N/A
Maximum Speed <sup>(1)</sup>		2 m/s		800 rpm 2000 rpm (-HS option)
Tube Capacity		N/A		10 mm (ER16, Dry Cut) 5.8 mm (ER16, Wet Cut)
Maximum Force (Continuous)		306.6 N		N/A
Maximum Torque (Continuous)		N/A		2.3 N·m (Dry Cut) 1.6 N·m (Wet Cut)
Load Capacity <sup>(2)</sup>	Axial	3.0 kg		
	Radial	2.0 kg		
	Moment	3 N·m		
Moving Mass (Unloaded)		19 kg		N/A
Rotor Inertia (Unloaded)		N/A		0.0006 kg·m <sup>2</sup>
Stage Mass with Tooling Platforms		95 kg	100 kg	N/A
Collet Type <sup>(3)</sup>		N/A		ER16
Collet Runout <sup>(4)</sup>		N/A		<25 µm
Minimum System Air Pressure <sup>(5)</sup>		100 psig		
Material		Hardcoated Aluminum Stage Body, Hardened Stainless Steel Way Covers, Stainless Steel Collet Chuck		
MTBF (Mean Time Between Failure)		10,000 Hours		

## Notes:

1. Maximum speed based on stage capability. Requires selection of appropriate amplifier with sufficient voltage and current.
2. Maximum loads are mutually exclusive. Loading limits are due to the collet chuck mechanism. Contact Aerotech if part load requirements exceed specifications.
3. Collet chuck accepts Rego-fix ER collets manufactured to DIN6499 specifications only.
4. Measured TIR of precision gage pin chucked with an ultra-precision ER collet (DIN6499) 10 mm away from collet face.
5. Collet chuck mechanism is normally-closed. Collet mechanism required air to open collet chuck. Air supply must be dry and oil-less OR 99.99% pure nitrogen. Air or nitrogen must be filtered to 1 microns particle size or better.

## Electrical Specifications

Drive System	Direct-drive servomotor
Feedback System	Non-contact optical encoder, 1 Vpp Sinusoidal output
Maximum Bus Voltage	340 VDC

## Recommended Controller

A3200	Npaq Ndrive HLe Ndrive HPe
-------	----------------------------------

Mechanical Specifications		Linear Axis		Rotary Axis
Travel		200 mm	300 mm	±360 deg. continuous
Accuracy		±1 µm		Calibrated <sup>(1)</sup> : ±24 µrad (±5 arc sec) Uncalibrated: ±146 µrad (±30 arc sec)
Bidirectional Repeatability		±0.5 µm		±15 µrad (±3 arc sec)
Straightness		±2 µm	±3 µm	N/A
Flatness		±2 µm	±3 µm	N/A
Pitch		39 µrad (8 arc sec)	49 µrad (10 arc sec)	N/A
Yaw		39 µrad (8 arc sec)	49 µrad (10 arc sec)	N/A
Maximum Speed <sup>(2)</sup>		2 m/s		600 rpm
Tube Capacity		N/A		0.5-16 mm (ER25, Dry Cut) 1-12 mm (ER25, Wet Cut) 16-30 mm (ER40)
Maximum Force (Continuous)		306.6 N		N/A
Maximum Torque (Continuous)		N/A		5.06 N·m
Load Capacity <sup>(3)</sup>	Axial	10 kg (ER25), 15 kg (ER40)		
	Radial	5 kg (ER25), 10 kg (ER40)		
	Moment	6 N·m (ER25), 12 N·m (ER40)		
Moving Mass (Unloaded)		23 kg		N/A
Rotor Inertia (Unloaded)		N/A		0.006 kg·m <sup>2</sup>
Stage Mass with Tooling Platforms		95 kg	100 kg	N/A
Collet Type <sup>(4)</sup>		N/A		ER25, ER40
Collet Runout <sup>(5)</sup>		N/A		<25 µm
Minimum System Air Pressure <sup>(6)</sup>		100 psig		
Material		Hardcoated Aluminum Stage Body, Hardened Stainless Steel Way Covers, Stainless Steel Collet Chuck		
MTBF (Mean Time Between Failure)		10,000 Hours		

Notes:

- Requires Aerotech controller and part programming as a rotary axis.
- Maximum speed based on stage capability. Requires selection of appropriate amplifier with sufficient voltage and current.
- Maximum loads are mutually exclusive. Loading limits are due to the collet chuck mechanism. Contact Aerotech if part load requirements exceed specifications.
- Collect chuck accepts Rego-fix ER collets manufactured to DIN6499 specifications only.
- Measured TIR of precision gage pin chucked with an ultra-precision ER collet (DIN6499) 10 mm away from collet face.
- Collet chuck mechanism is normally-closed. Collet mechanism required air to open collet chuck. Air supply must be dry and oil-less OR 99.99% pure nitrogen. Air or nitrogen must be filtered to 1 microns particle size or better.

Electrical Specifications	
Drive System	Direct-drive servomotor
Feedback System	Non-contact optical encoder, 1 Vpp Sinusoidal output
Maximum Bus Voltage	340 VDC

Recommended Controller	
A3200	Npaq Ndrive HLe Ndrive HPe

# Vasculathe® ACS Series DIMENSIONS

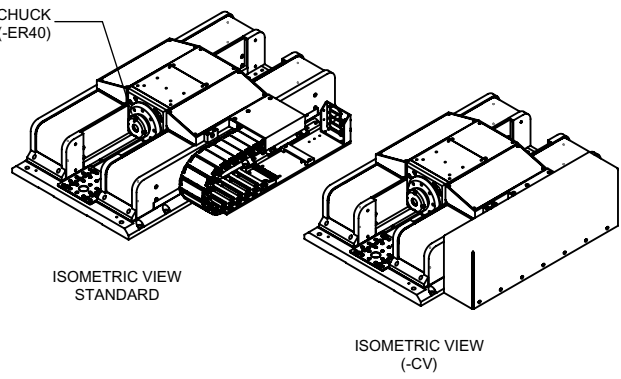
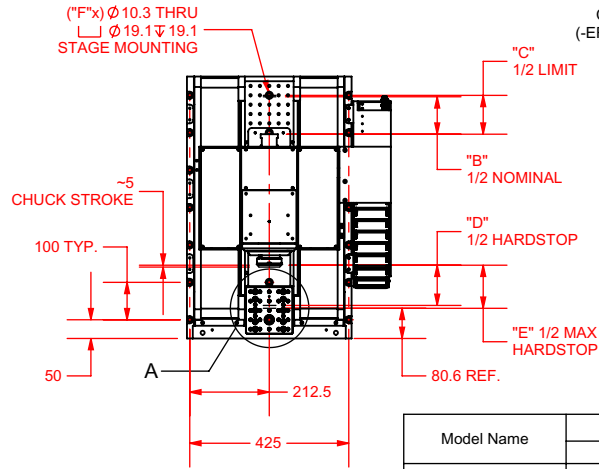

Model Name	Dimensions- Millimeters						
	Travel	A	B	C	D	E	F
Vasculathe-ACS-200	200	700	100	104.5	107.5	115.2	20
Vasculathe-ACS-300	300	800	150	154.5	157.5	165.2	22

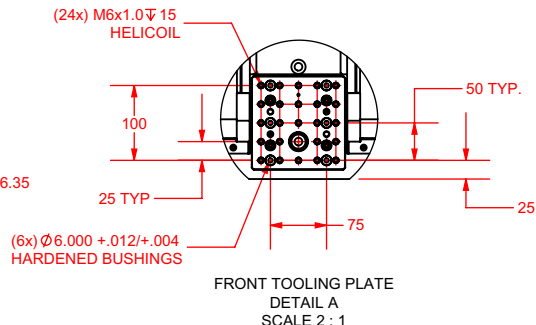
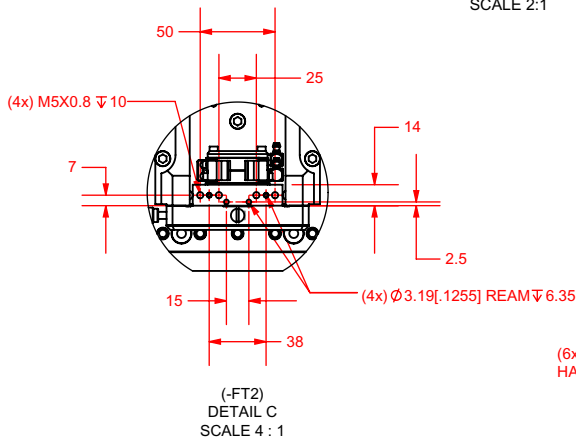
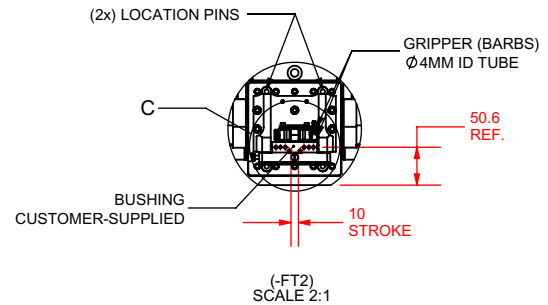
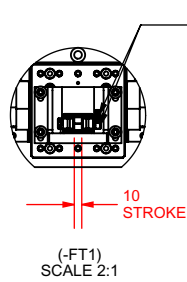
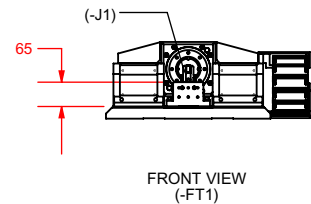
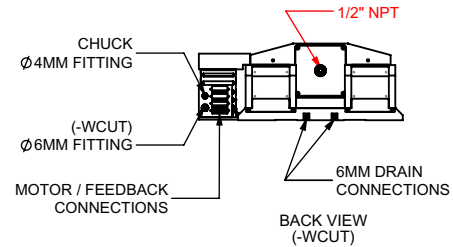
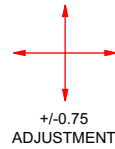
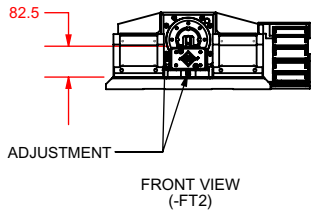
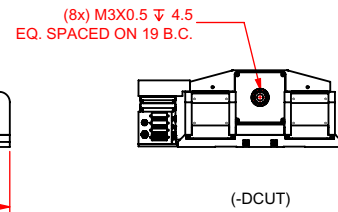
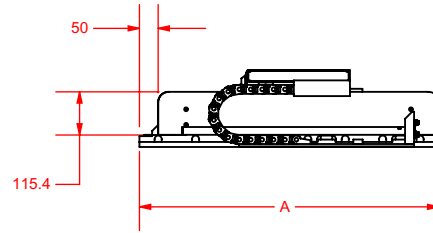
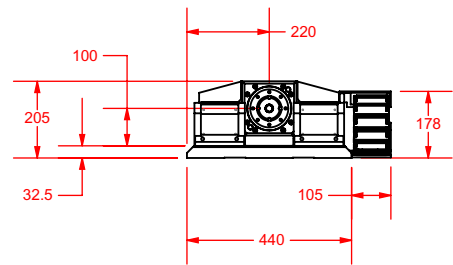

DIMENSIONS: MILLIMETERS [INCHES]

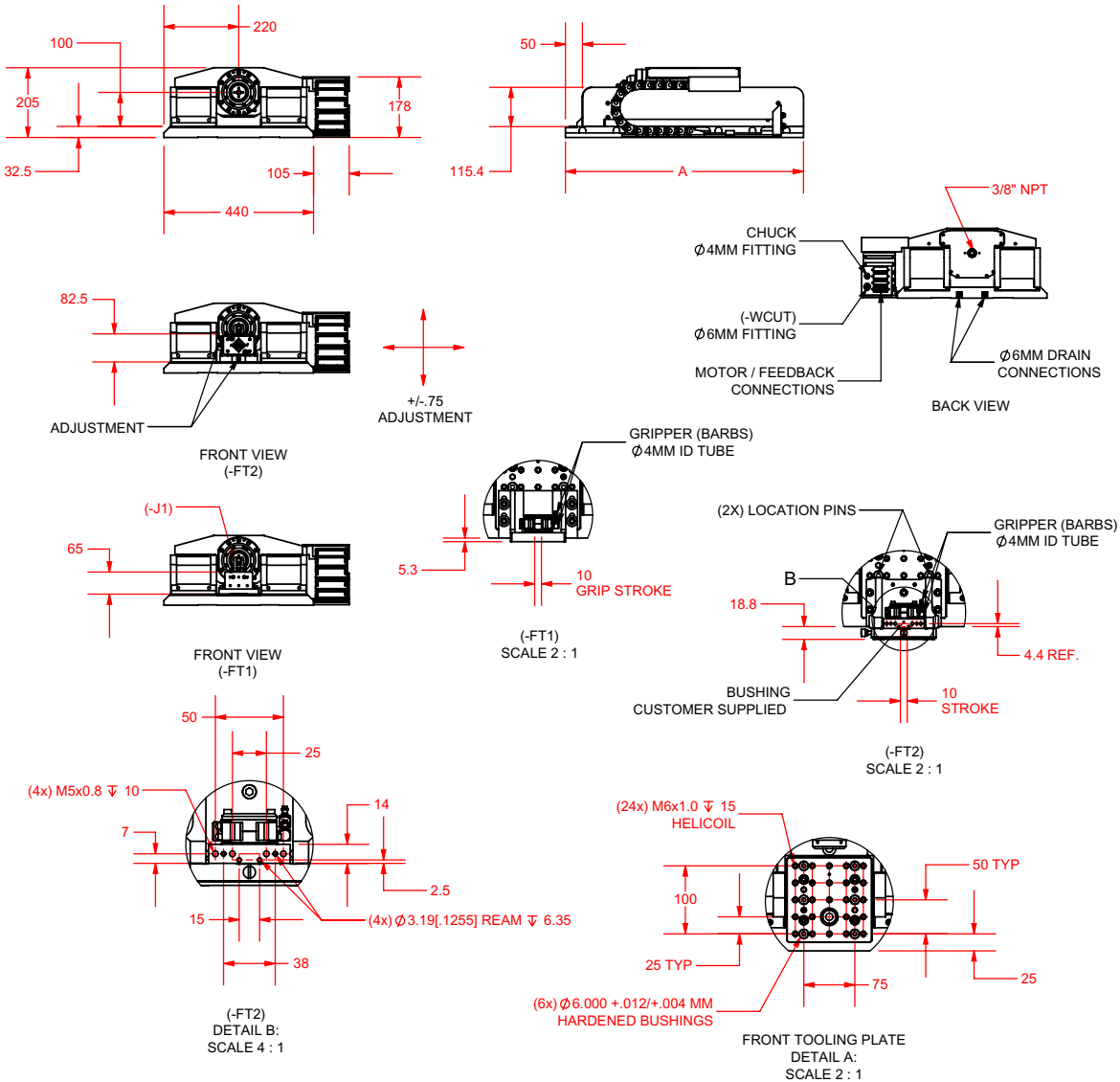
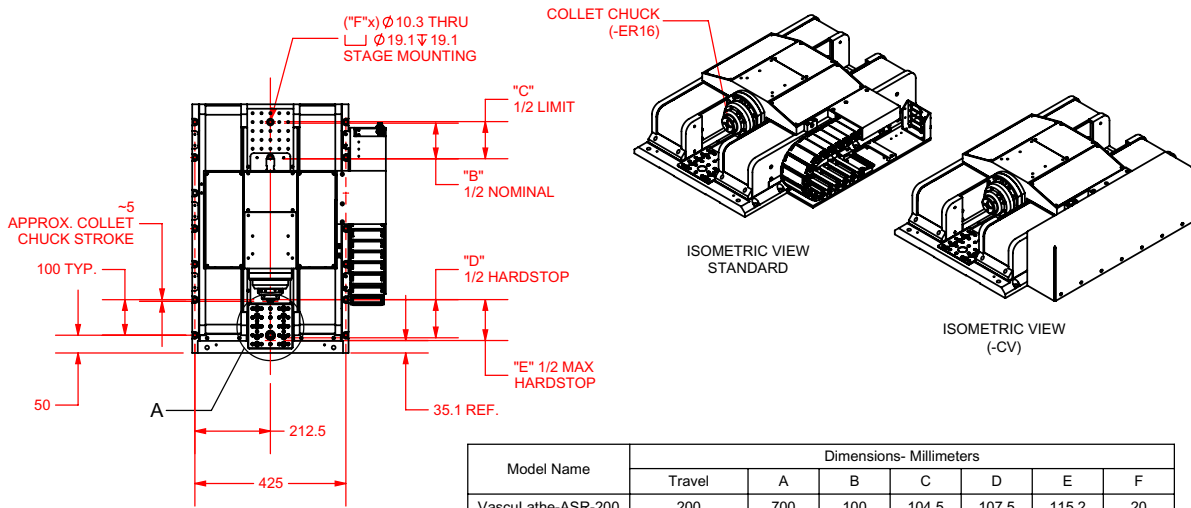

DIMENSIONS: MILLIMETERS

## VascuLathe-ASR Linear/Rotary Motion Platform ORDERING INFORMATION

### Travel (Required)

-200	200 mm linear axis travel
-300	300 mm linear axis travel

### Rotary Speed (Required)

-SS	Standard speed rotary axis
-HS	High speed rotary axis

### Cutting Configuration (Required)

-DCUT	Dry cutting configuration
-WCUT	Wet cutting configuration with fluid rotary union

### Cover (Optional)

-CV	Protective cable cover for linear axis
-----	--

### Front Tooling (Optional)

-FT1	Front tooling platform with gripper
-FT2	Front tooling platform with alignment gripper

### Gripper Jaws (Optional)

-J1	Gripper jaws for 0-10 mm tube diameters
-----	---

### Integration (Required)

Aerotech offers both standard and custom integration services to help you get your system fully operational as quickly as possible. The following standard integration options are available for this system. Please consult Aerotech if you are unsure what level of integration is required, or if you desire custom integration support with your system.

-TAS	Integration - Test as system Testing, integration, and documentation of a group of components as a complete system that will be used together (ex: drive, controller, and stage). This includes parameter file generation, system tuning, and documentation of the system configuration.
-TAC	Integration - Test as components Testing and integration of individual items as discrete components that ship together. This is typically used for spare parts, replacement parts, or items that will not be used together. These components may or may not be part of a larger system.

### Accessories (to be ordered as separate line item)

Collet-ER16-CLTxxx	ER16 collet - consult with Aerotech for available sizes
RingSeal-ER16-RSxx	Ring seal for wet cutting - consult with aerotech for available sizes
CGF	<a href="#">Collet and Gripper Filtration Kit</a>

## Vasculathe-ACS Linear/Rotary Motion Platform ORDERING INFORMATION

### Travel (Required)

-200	200 mm linear axis travel
-300	300 mm linear axis travel

### Collet Style (Required)

-ER25	ER25 ultra-precision collet chuck
-ER40	ER40 ultra-precision collet chuck

### Cutting Configuration (Required)

-DCUT	Dry cutting configuration
-WCUT	Wet cutting configuration with fluid rotary union

### Cover (Optional)

-CV	Protective cable cover for linear axis
-----	--

### Front Tooling (Optional)

-FT1	Front tooling platform with gripper
-FT2	Front tooling platform with alignment gripper

### Gripper Jaws (Optional)

-J1	Gripper jaws for 0-10 mm tube diameters
-J2	Gripper jaws for 8-18 mm tube diameters
-J3	Gripper jaws for 16-26 mm tube diameters
-J4	Gripper jaws for 24-34 mm tube diameters

### Metrology - Rotary (Required)

-PL1	Metrology, Uncalibrated with Performance Plots
-PL2	Metrology, Calibrated (HALAR) with Performance Plots

*Metrology option applies to rotary axis only.*

### Integration (Required)

Aerotech offers both standard and custom integration services to help you get your system fully operational as quickly as possible. The following standard integration options are available for this system. Please consult Aerotech if you are unsure what level of integration is required, or if you desire custom integration support with your system.

-TAS	Integration - Test as system Testing, integration, and documentation of a group of components as a complete system that will be used together (ex: drive, controller, and stage). This includes parameter file generation, system tuning, and documentation of the system configuration.
-TAC	Integration - Test as components Testing and integration of individual items as discrete components that ship together. This is typically used for spare parts, replacement parts, or items that will not be used together. These components may or may not be part of a larger system.

### Accessories (to be ordered as separate line item)

Collet-ER25-CLTxxx	ER25 collet - consult with Aerotech for available sizes
Collet-ER40-CLTxxx	ER40 collet - consult with Aerotech for available sizes
RingSeal-ER25-RSxx	Ring seal for wet cutting, ER25 collet - consult with Aerotech for available sizes
RingSeal-ER40-RSxx	Ring seal for wet cutting, ER40 collet - consult with Aerotech for available sizes
CGF	<a href="#">Collet and Gripper Filtration Kit</a>